

VIHUNG VALVE

VHV[®]

**FORGED
STEEL
VALVES**

BALL, GATE, GLOBE & CHECK



CHINA VIHUNG VALVE CO., LTD.



COMPANY PROFILE

VIHUNG VALVE specialises in the supply of valves for the Oil, Gas, Chemical, Petrochemical, Pipeline and Water Industries Worldwide. Our valves are used in Offshore, Onshore and Sub-Sea applications.

The Management of the Company has many years experience in the Valve Industry. The organisation and flexibility of the Company allows **VIHUNG VALVE** to offer short lead-times, even on non-standard valves.

All valves are supplied to the highest quality standards and are fully tested before leaving the factory.

The aim of **VIHUNG VALVE** is to provide valves and services, which meet or exceed our Customers' requirements, at a realistic price and reliable manufacturing time and in so doing remain a market leader supplying a worldwide base of industry leading clients.

VIHUNG VALVE QUALITY SYSTEM

VIHUNG VALVE quality system is Lloyds approved to BS: EN ISO 9001:2015 and API Q1 9th Edition which ensures that our product is controlled through each stage of manufacture. Valves are supplied with full chemical and mechanical material test certificates to BS EN 10204: 2004 3.1. Hydrostatic and pneumatic test certificates are also supplied with each valve.

VIHUNG VALVE is part of the **Federal International (2000) Ltd Group**. This long standing relationship coupled with our own experience has allowed **VIHUNG VALVE** to grow and develop into our current and ever improving place within the market.

As part of a large multi-national group, **VIHUNG VALVE** has the benefit and experience of our The PR. of China based operations together with worldwide access to our parent company resources and our numerous sister companies.

These valuable resources afford us global reach, whilst allowing local access and understanding of both global and local markets, allowing us to provide local technical support in almost any region.

Our key position within the group enables us to offer full management and supply of valves, services and subsidiary equipment. We also offer access to a large and continuously replenished inventory of our core in-house designed products and all others available within the group.

We can supply large quantities of varying product ranges almost instantly or equally manufacture at our various **VIHUNG VALVE** controlled manufacturing sites with short lead times and impeccable quality.

REFERENCE STANDARDS

AMERICAN STANDARDS (ANSI, ASME)	
ANSI / ASME B16.5	Pipe flanges and flanged fittings.
ANSI / ASME B16.10	Face - to -face and end - to - end dimension of valves
ANSI / ASME B16.25	Butt -weld ends.
ANSI / ASME B16.34	Valves -flanged, thread and weld ends.
ASME B16.11	Forged Fittings, Socket Welding and Threaded
ASME B1.20.1	Pipe Threads, General Purpose, Inch
ASTM	Material specifications of material used.
API STANDARDS (API)	
API 6D	Specification for pipeline valves.
API 602	Specification for Steel Gate Globe Check valves for Size NPS 4 and Smaller.
API 6FA	Specification for fire test for valves.
API 607	Fire test for soft - seated quarter - turn valves.
API 598	Valve inspection and testing.
API 5L	Specification for line pipe.
BRITISH STANDARDS (BS)	
BS 5351	Steel ball valves for the petroleum, petrochemical and allied instrument.
BS 6755	Testing of valves. Specification for fire-type testing requirements.
MSS STANDARDS (MSS SP)	
SP 25	Standard marking system for valves, fittings, flanges and unions.
SP 55	Quality Standards for Steel Casting, Visual Method
INTERNATIONAL STANDARDS	
ISO 5208	Industrial Valves – Pressure Testing of Metallic Valves
ISO 5211	Industrial Valves – Part Turn Actuator Attachments
EN ISO 17292	Metal Ball Valves for Petroleum, Petrochemical and allied industries.
EN 10204	Types of inspection documents.
NACE MR 01-75	Sulphide stress cracking resistant materials.



FORGED STEEL GATE VALVES

CONSTRUCTION & FEATURES

- Designed to API 602, ASME B16:34
- Standard Bore and Full Bore
- Outside screw and yoke (OS & Y)
- Two piece self-aligning packing gland
- Bolted bonnet & spiral wound gasket seal bonnet
- Welded bonnet or threaded and pressure seal bonnet
- Integral backseat
- Various types of end connections available

VH

MAIN COMPONENT & PARTS

1. BODY:

Strong and Robust in ASTM forged steel material. Designed to the requirements of API 602 and ASME B16.34. Available in Standard and Full Bore design.

2. SEAT:

Part of the valve trim to API 602, the body seat is a separate seat ring pressed and seal welded into the valve body. This eliminates potential leak paths.

3. WEDGE:

Part of the valve trim to API 602, the wedge is in ASTM forged steel material. Solid wedge as standard.

4. STEM:

Part of the valve trim to API 602, the stem is in ASTM forged steel material and designed to the basic dimensional requirements of API 602. Comes with an integral backseat shoulder that seals with the integral backseat of the bonnet.

5. GASKET:

Spiral Wound Type body gasket as standard.

6. BONNET:

Strong and Robust in ASTM forged steel material. Designed to the requirements of API 602 and ASME B16.34. Comes with an integral backseat and stuffing box.

7. GLAND PACKING:

Graphite packing as standard. Other materials available upon request.

8. GLAND:

Alloy steel material to ASTM standards.

9. GLAND FLANGE:

The gland and gland flange is designed as a separate two piece assembly. This self aligning feature allows the gland flange to be tightened unevenly while the gland maintains its parallel alignment with the stem and stuffing box.

10. GLAND BOLT/NUT:

Stainless Steel Material to ASTM standards. The gland bolt/nut assembly is a stud, double nut arrangement. This allows complete removal during servicing of the valve.

11. BONNET BOLT:

Alloy steel material to ASTM standards.

12. HANDWHEEL:

Durable and Robust design. Ease of operation with the appropriate sizing.

13. NAMEPLATE:

Allows full traceability.

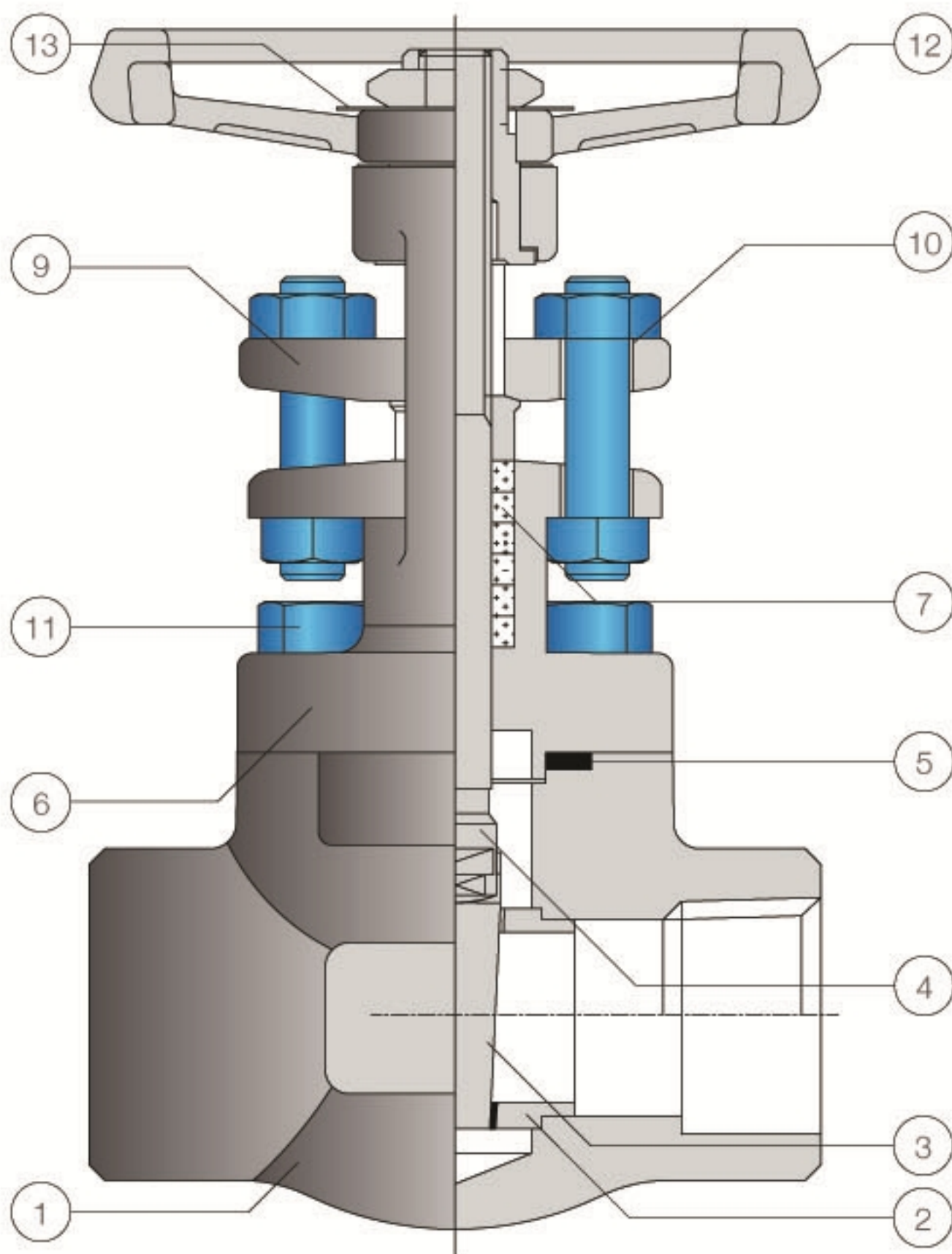

CLASS 800# GATE VALVES

Socket Weld & Threaded Ends Standard Bore.

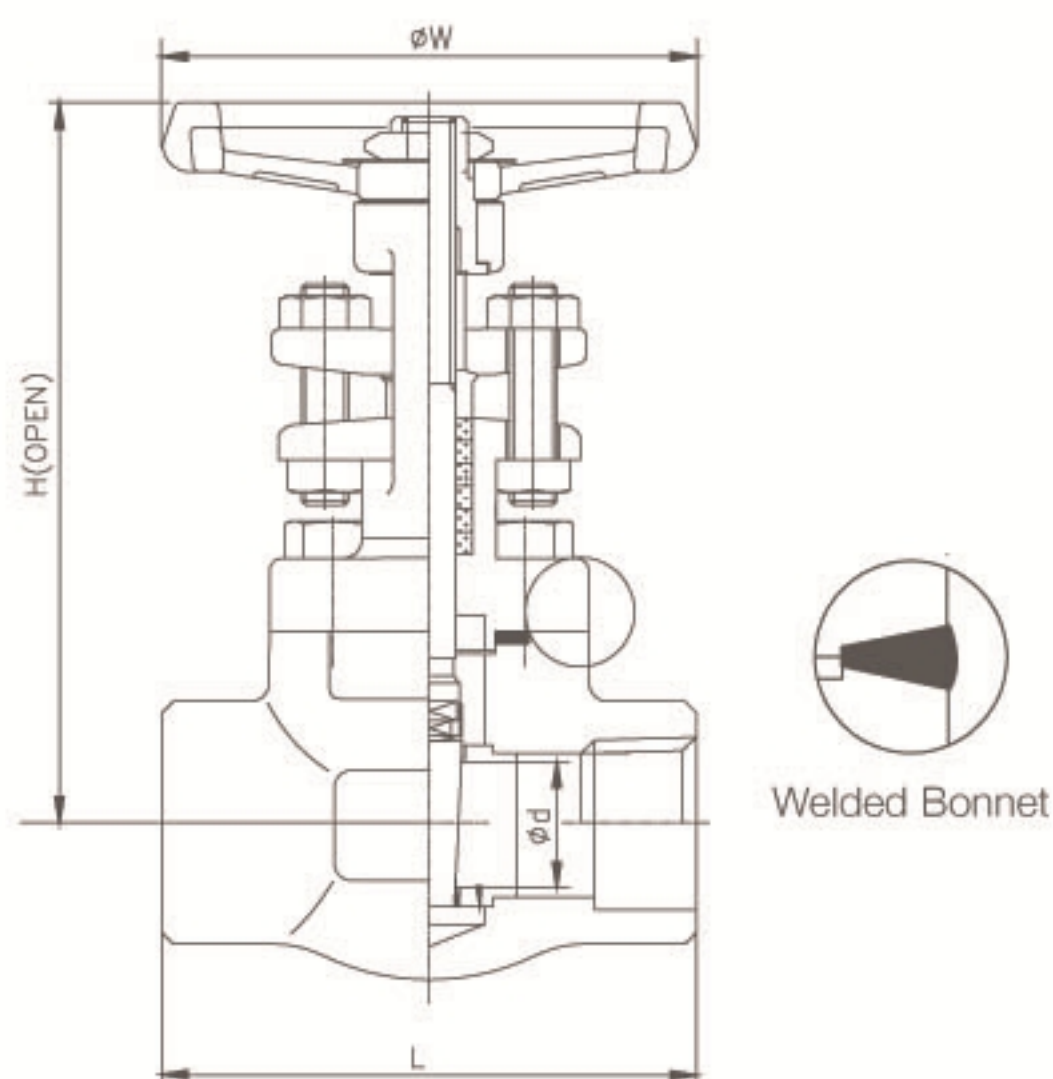

SPECIFICATION

Valve Body Pressure Rating

Class 800, Max 1975 psig @ 100 F (Carbon Steel)

Temperature Rating

As per ASME B16.34

Body Construction

Bolted Bonnet, Outside Screw and Yoke
Welded Bonnet, Outside Screw and Yoke
Pup Piece welding or
Extended ends available upon request.
Other Constructions: Bellow Seals, Extended stem,
Live Loading Packing, etc.. available upon request.

Body Bolts

ASTM A193 Gr B7 or B8 (N/A to Welded Bonnet)
(Other Options available upon request)

Seats

Full/Half HF (Hardfaced Stellite #6) seats or
Non HF seats available

Operation

Manual - Handwheel Operator

Seat / Seal Leakage

Conform to API 598.

Design Specification

API 602
ASME 16.34
Socket Weld Ends to ASME B16.11
Threaded Ends to ASME B1.20.1
End to End (L) dimensions are to manufacturer standard
NACE MR-01-75 material (when required)
Materials to ASTM standards
Special Materials are available to customer requirements

STANDARD COMPONENT MATERIALS

NO	DESCRIPTION	A105N /HF	LF2/HF	F304(L) /HF	F316(L) /HF	F51/HF
1	BODY	A105N	LF2	F304(L)	F316(L)	F51
2	SEAT			HF		
3	WEDGE			HF		
4	STEM	F6A	F6A	F304(L)	F316(L)	F51
5	GASKET	SPW 316 + GRAPHITE		SPW 304 + GRAPHITE	SPW 316 + GRAPHITE	
6	BONNET	A105N	LF2	F304(L)	F316(L)	F51
7	GLAND PACKING	GRAPHITE				
8	GLAND	410	410	F304(L)	F316(L)	F51
9	GLAND FLANGE	CS	LTCS	SS	SS	SS
10	GLAND BOLT/NUT	B8/8				
11	BONNET BOLT	B7	L7	B8	B8	B8
12	HANDWHEEL	A197				
13	NAME PLATE	SS				

NOTE: (L) Refers to Material available in Low Carbon as an option as well.
Other materials available to customer requirement.

DIMENSION TABLE

(UNIT - mm)

SIZE	L	d	H	W	WEIGHT(kg) (Approx.)	CV FACTORS
1/2"	79	9.5	158	100	2	5.5
3/4"	92	12.7	163	100	2.5	12
1"	111	17.5	197	120	3.6	27
1 1/4"	118	23	225	150	4.8	55
1 1/2"	118	28.6	247	150	5.5	80
2"	132	36.5	267	150	7.5	105

NOTE: Other Sizes and Full Bore Options available upon request.
Dimensions are for information only. Order Specific arrangement drawing dimensions will be final.

CLASS 1500# GATE VALVES

Socket Weld & Threaded Ends Standard Bore.

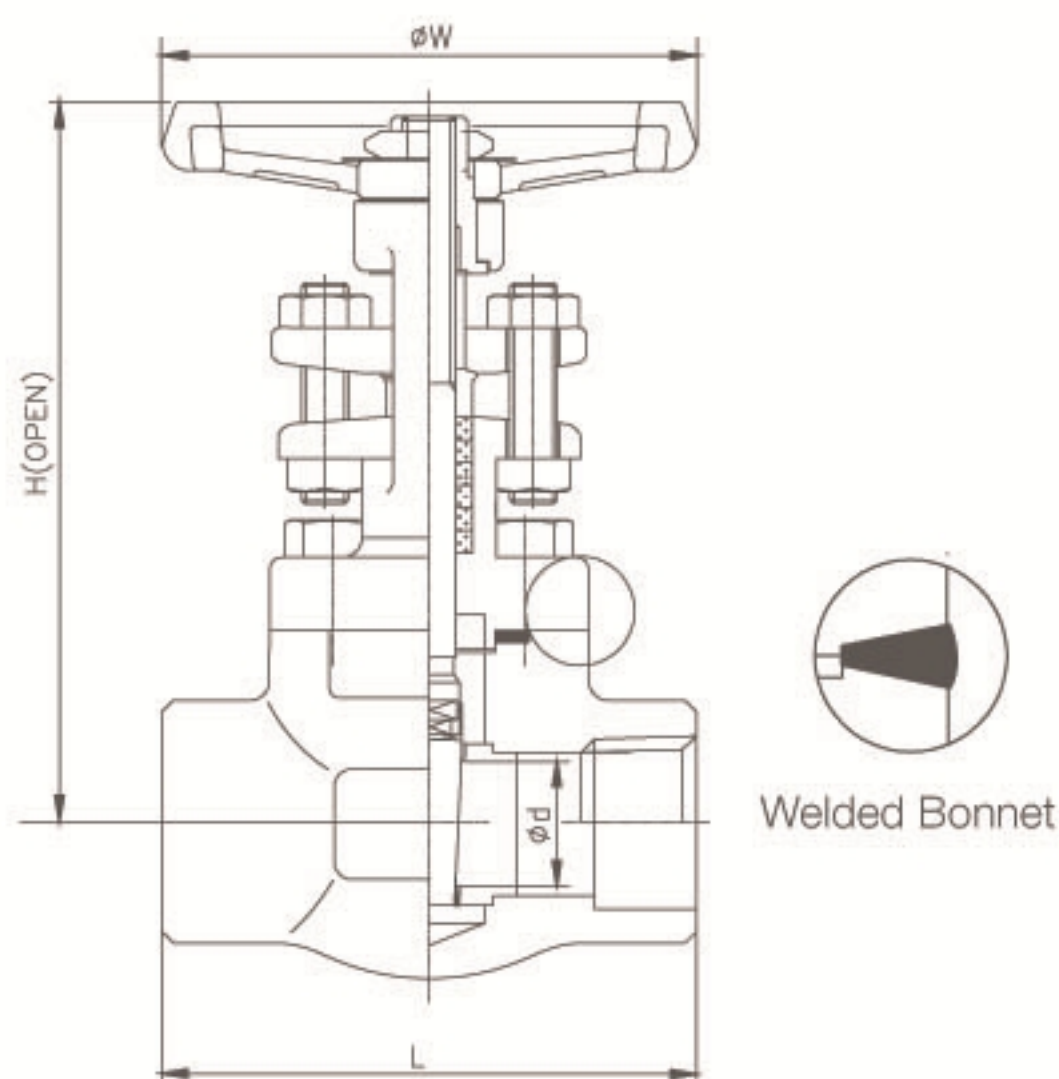

SPECIFICATION

Valve Body Pressure Rating

Class 1500, Max 3705 psig @ 100 F (Carbon Steel)

Temperature Rating

As per ASME B16.34

Body Construction

Bolted Bonnet, Outside Screw and Yoke
Welded Bonnet, Outside Screw and Yoke
Pup Piece welding or
Extended ends available upon request.
Other Constructions: Bellow Seals, Extended stem,
Live Loading Packing, etc.. available upon request.

Body Bolts

ASTM A193 Gr B7 or B8 (N/A to Welded Bonnet)
(Other Options available upon request)

Seats

Full/Half HF (Hardfaced Stellite #6) seats or
Non HF seats available

Operation

Manual - Handwheel Operator

Seat / Seal Leakage

Conform to API 598.

Design Specification

API 602
ASME B16.34
Socket Weld Ends to ASME B16.11
Threaded Ends to ASME B1.20.1
End to End (L) dimensions are to manufacturer standard
NACE MR-01-75 material (when required)
Materials to ASTM standards
Special Materials are available to customer requirements

STANDARD COMPONENT MATERIALS

NO	DESCRIPTION	A105N /HF	LF2/HF	F304(L) /HF	F316(L) /HF	F51/HF
1	BODY	A105N	LF2	F304(L)	F316(L)	F51
2	SEAT			HF		
3	WEDGE			HF		
4	STEM	F6A	F6A	F304(L)	F316(L)	F51
5	GASKET	SPW 316 + GRAPHITE		SPW 304 + GRAPHITE	SPW 316 + GRAPHITE	
6	BONNET	A105N	LF2	F304(L)	F316(L)	F51
7	GLAND PACKING	GRAPHITE				
8	GLAND	410	410	F304(L)	F316(L)	F51
9	GLAND FLANGE	CS	LTCS	SS	SS	SS
10	GLAND BOLT/NUT	B8/8				
11	BONNET BOLT	B7	L7	B8	B8	B8
12	HANDWHEEL	A197				
13	NAME PLATE	SS				

NOTE: (L) Refers to Material available in Low Carbon as an option as well.
Other materials available to customer requirement.

DIMENSION TABLE

(UNIT - mm)

SIZE	L	d	H	W	WEIGHT(kg) (Approx.)	CV FACTORS
1/2"	92	9.5	166	100	2.25	5.5
3/4"	111	12.7	196	120	3.75	12
1"	118	17.5	226	150	5.4	27
1 1/4"	118	23	250	150	5.9	55
1 1/2"	132	28.5	270	180	8.5	80
2"	150	36.5	315	200	13.65	105

NOTE: Other Sizes and Full Bore Options available upon request.
Dimensions are for information only. Order Specific arrangement drawing dimensions will be final.

CLASS 150# - 300# - 600# GATE VALVES

Flanged Ends Standard Bore.

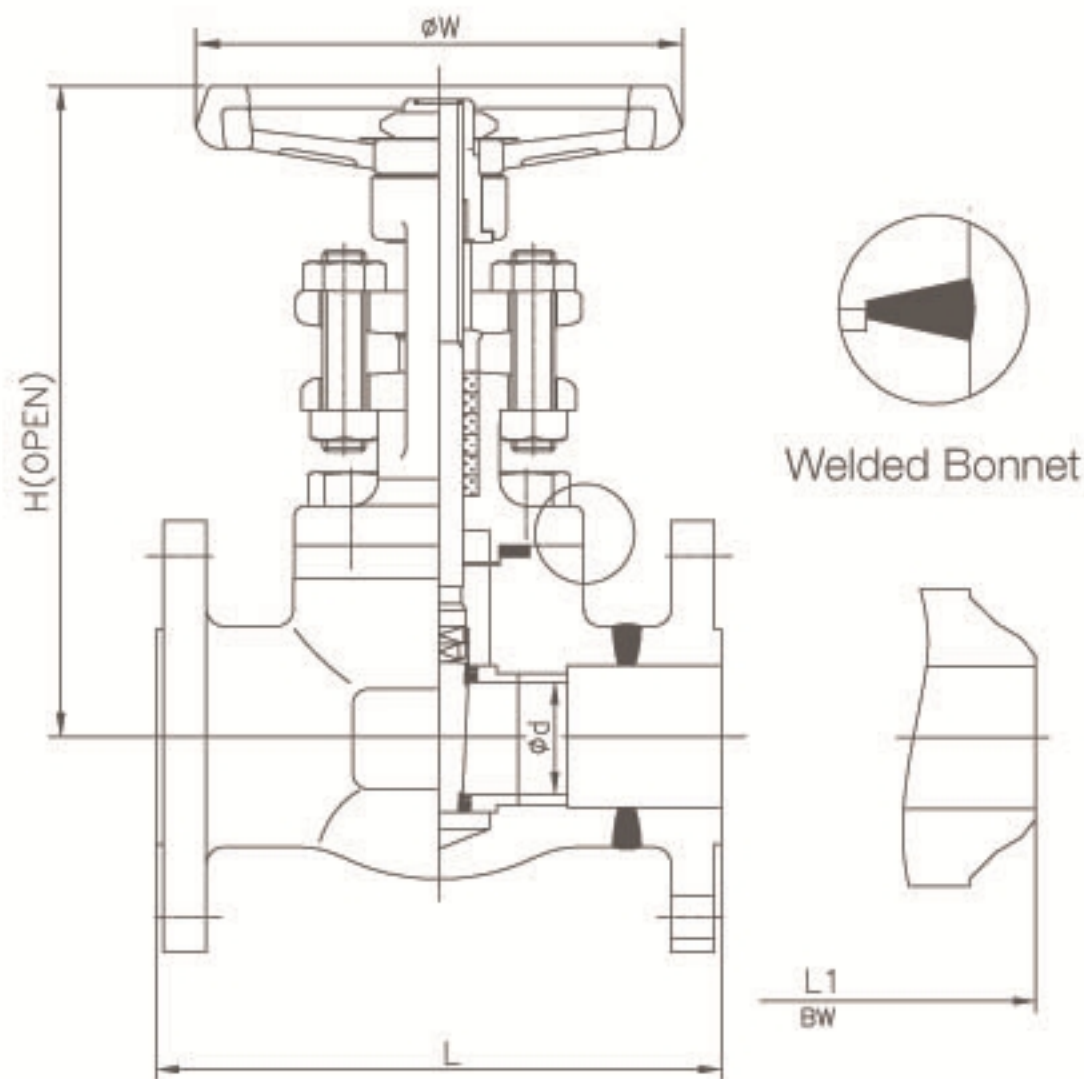

SPECIFICATION

Valve Body Pressure Rating

Class 150, Max 285 psig @ 100 F (Carbon Steel)
Class 300, Max 740 psig @ 100 F (Carbon Steel)
Class 600, Max 1480 psig @ 100 F (Carbon Steel)

Temperature Rating

As per ANSI B16.34

Body Construction

Bolted Bonnet, Outside Screw and Yoke
Welded Bonnet, Outside Screw and Yoke
Integral and Welded Flange available depending on size and rating.
Other Constructions: Bellow Seals, Extended stem, Live Loading Packing, etc.. available upon request.

Body Bolts

ASTM A193 Gr B7 or B8 (N/A to Welded Bonnet)
(Other Options available upon request)

Seats

Full/Half HF (Hardfaced Stellite #6) seats or
Non HF seats available

Operation

Manual - Handwheel Operator

Seat / Seal Leakage

Conform to API 598.

Design Specification

API 602
ASME B16.34
Flange Ends to ASME B16.5
Butt Weld Ends to ASME B16.25
Face to Face to ASME B1.20.1
NACE MR-01-75 material (where required)
Materials to ASTM standards
Special Materials are available to customer requirements

STANDARD COMPONENT MATERIALS

NO	DESCRIPTION	A105N /HF	LF2/HF	F304(L) /HF	F316(L) /HF	F51/HF
1	BODY	A105N	LF2	F304(L)	F316(L)	F51
2	SEAT			HF		
3	WEDGE			HF		
4	STEM	F6A	F6A	F304(L)	F316(L)	F51
5	GASKET	SPW 316 + GRAPHITE		SPW 304 + GRAPHITE	SPW 316 + GRAPHITE	
6	BONNET	A105N	LF2	F304(L)	F316(L)	F51
7	GLAND PACKING	GRAPHITE				
8	GLAND	410	410	F304(L)	F316(L)	F51
9	GLAND FLANGE	CS	LTCS	SS	SS	SS
10	GLAND BOLT/NUT	B8/8				
11	BONNET BOLT	B7	L7	B8	B8	B8
12	HANDWHEEL	A197				
13	NAME PLATE	SS				

NOTE: (L) Refers to Material available in Low Carbon as an option as well.
Other materials available to customer requirement.

DIMENSION TABLE

(UNIT - mm)

NOTE: 1/2" to 2" Integral Flange

SIZE	L, L1			d	H		W	WEIGHT(kg) (Approx.)						CV FACTORS
	CL 150	CL 300	CL 600		CL 150	CL 300 CL 600		CL 150		CL 300		CL 600		
								RF	BW	RF	BW	RF	BW	
1/2"	108	140	165	9.5	144	148	100	2.6	2.0	3.2	2.8	3.5	2.9	5.5
3/4"	117	152	190	12.7	150	156	100	3.3	3.8	4.7	4.1	4.8	4.0	12
1"	127	165	216	17.5	182	180	120	4.9	4.2	6.3	5.7	6.3	5.7	27
1 1/4"	140	178	229	23	216	228	150	8.4	7.8	9.6	8.1	9.6	8.1	55
1 1/2"	165	190	241	28.6	235	274	150	9.0	8.0	11.4	9.2	10.1	8.9	80
2"	178	216	292	36.5	270	270	150	12.1	12	15.4	13.1	13.9	11.8	105

NOTE: Other Sizes and Full Bore Options available upon request.
Dimensions are for information only. Order Specific arrangement drawing dimensions will be final.

CLASS 1500# GATE VALVES

Flanged Ends Standard Bore.

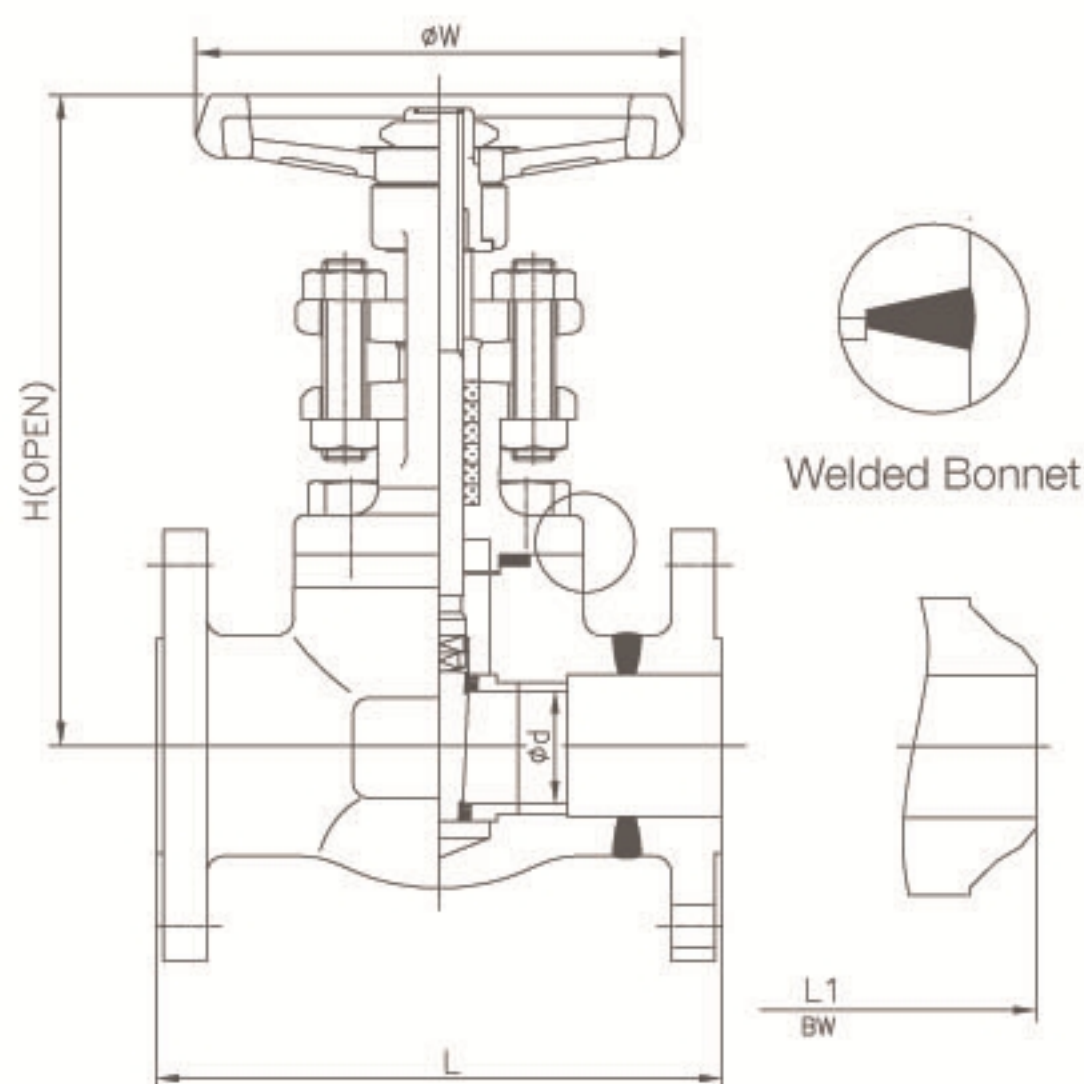

SPECIFICATION

Valve Body Pressure Rating

Class 1500, Max 3705 psig @ 100 F (Carbon Steel)

Temperature Rating

As per ASME B16.34

Body Construction

Bolted Bonnet, Outside Screw and Yoke
Welded Bonnet, Outside Screw and Yoke
Integral and Welded Flange available depending on size and rating.
Other Constructions: Bellow Seals, Extended stem, Live Loading Packing, etc.. available upon request.

Body Bolts

ASTM A193 Gr B7 or B8 (N/A to Welded Bonnet)
(Other Options available upon request)

Seats

Full/Half HF (Hardfaced Stellite #6) seats or
Non HF seats available

Operation

Manual - Handwheel Operator

Seat / Seal Leakage

Conform to API 598.

Design Specification

API 602
ASME B16.34
Flange Ends to ASME B16.5
Butt Weld Ends to ASME B16.25
Face to Face to Manufacturer's standard
NACE MR-01-75 material (when required)
Materials to ASTM standards
Special Materials are available to customer requirements

STANDARD COMPONENT MATERIALS

NO	DESCRIPTION	A105N /HF	LF2/HF	F304(L) /HF	F316(L) /HF	F51/HF
1	BODY	A105N	LF2	F304(L)	F316(L)	F51
2	SEAT			HF		
3	WEDGE			HF		
4	STEM	F6A	F6A	F304(L)	F316(L)	F51
5	GASKET	SPW 316 + GRAPHITE		SPW 304 + GRAPHITE	SPW 316 + GRAPHITE	
6	BONNET	A105N	LF2	F304(L)	F316(L)	F51
7	GLAND PACKING	GRAPHITE				
8	GLAND	410	410	F304(L)	F316(L)	F51
9	GLAND FLANGE	CS	LTCS	SS	SS	SS
10	GLAND BOLT/NUT	B8/8				
11	BONNET BOLT	B7	L7	B8	B8	B8
12	HANDWHEEL	A197				
13	NAME PLATE	SS				

NOTE: (L) Refers to Material available in Low Carbon as an option as well.
Other materials available to customer requirement.

DIMENSION TABLE

(UNIT - mm)

NOTE: 1/2" to 2" Integral Flange

SIZE	L		d	H	W	WEIGHT(kg) (Approx.)	CV FACTORS
	L(RF), L1(BW)	L(RTJ)					
1/2"	216	216	9.5	166	100	5	5.5
3/4"	229	229	12.7	196	120	7	12
1"	254	254	17.5	226	150	18.5	27
1 1/4"	279	279	23	250	150	28	55
1 1/2"	305	305	28.5	270	180	29	80
2"	368	371	36.5	315	200	34	105

NOTE: Other Sizes and Full Bore Options available upon request.
Dimensions are for information only. Order Specific arrangement drawing dimensions will be final.

CLASS 2500# HIGH PRESSURE GATE VALVES

Pressure Seal Bonnet, Socket Weld & Threaded Ends.

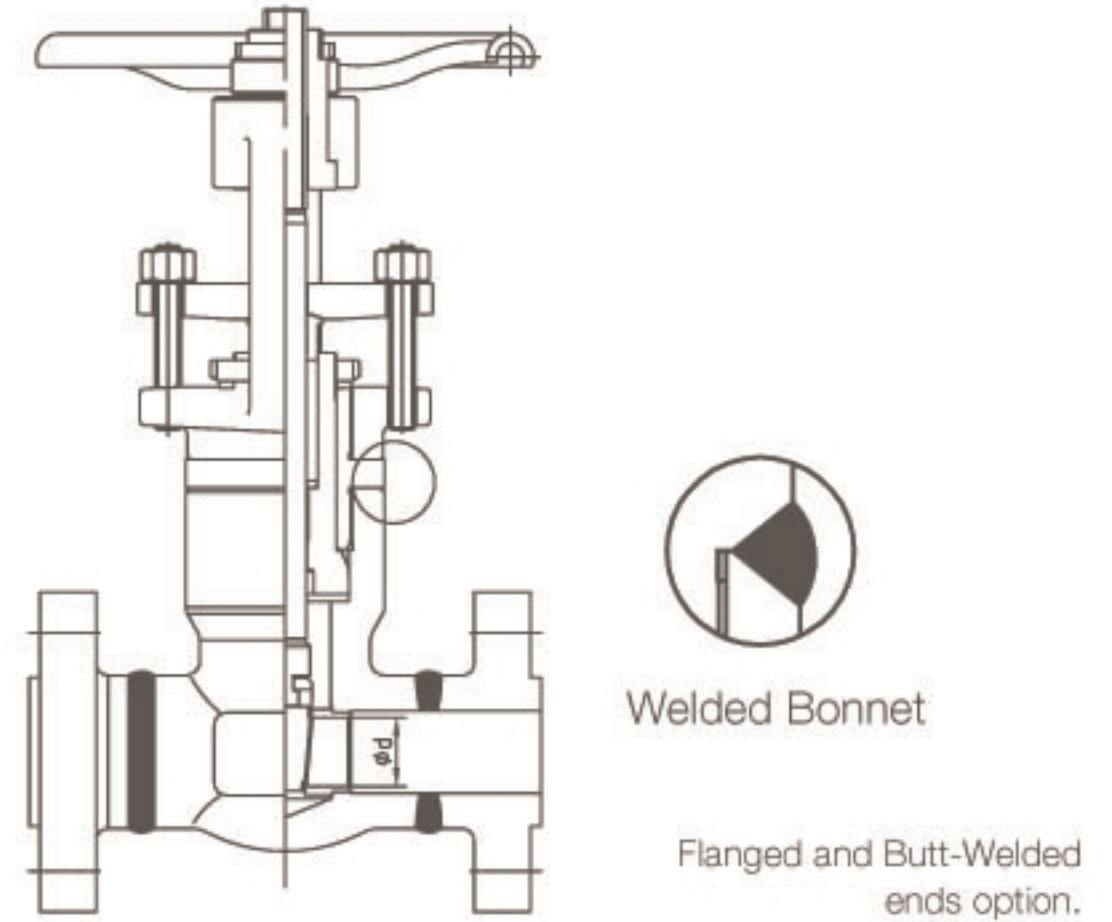
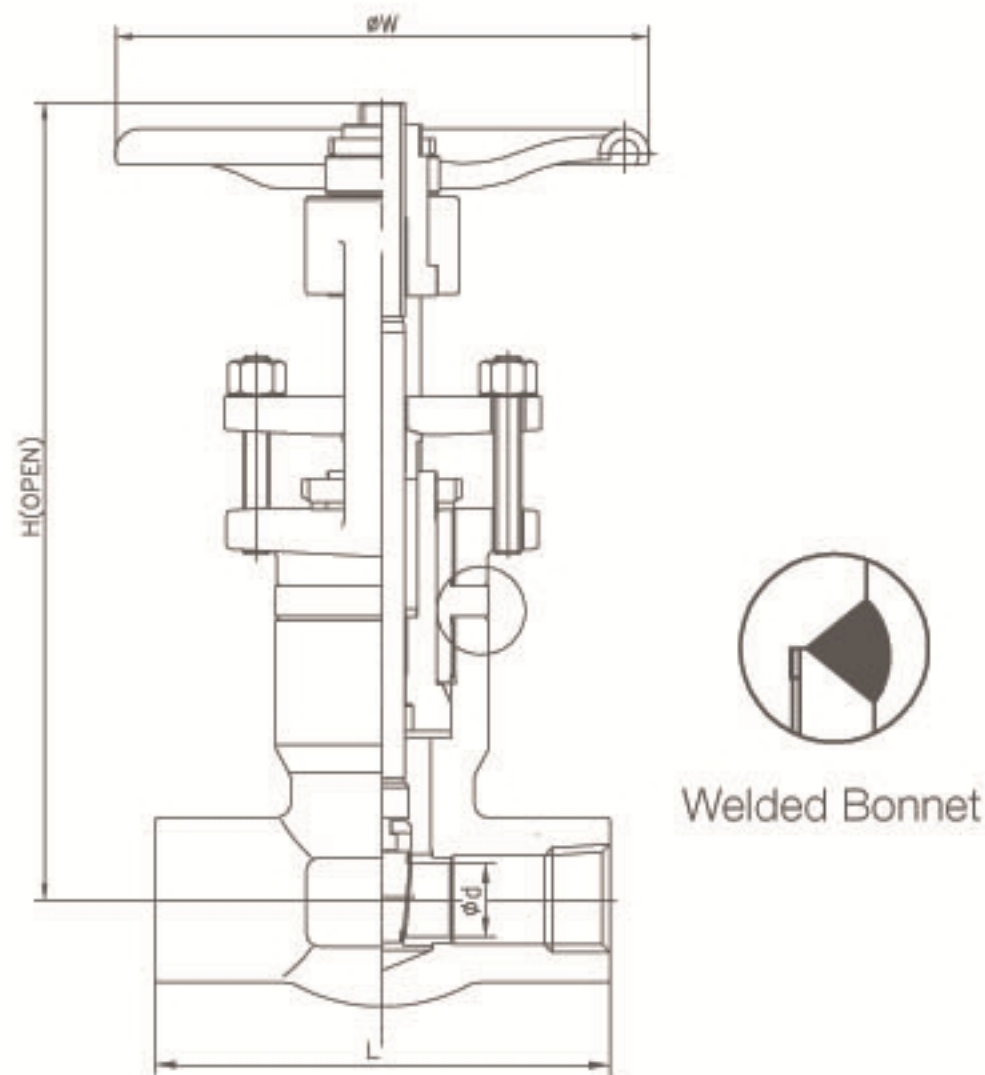

STANDARD COMPONENT MATERIALS

NO	DESCRIPTION	A105N /HF	LF2/HF	F304(L) /HF	F316(L) /HF	F51/HF
1	BODY	A105N	LF2	F304(L)	F316(L)	F51
2	SEAT			HF		
3	WEDGE			HF		
4	STEM	F6A	F6A	F304(L)	F316(L)	F51
5	PRESSURE SEAL RING			SS		
6	GASKET			SS		
7	BONNET	A105N	LF2	F304(L)	F316(L)	F51
8	GLAND PACKING			GRAPHITE		
9	GLAND	410	410	F304(L)	F316(L)	F51
10	GLAND FLANGE	CS	LTCS	SS	SS	SS
11	GLAND BOLT/NUT			B8/8		
12	HANDWHEEL			A197		
13	NAME PLATE			SS		

NOTE: (L) Refers to Material available in Low Carbon as an option as well.
Other materials available to customer requirement.

DIMENSION TABLE

(UNIT - mm)

SIZE	L	d	H	W	WEIGHT(kg) (Approx.)
1/2"	155	10	280	200	8
3/4"	155	13.5	280	200	10.5
1"	155	17.5	315	250	10.5
1 1/4"	186	23	488	300	15
1 1/2"	232	28.5	488	300	40
2"	284	36.5	535	350	50

NOTE: Dimensions are for information only.
Order Specific arrangement drawing dimensions will be final.

SPECIFICATION

Valve Body Pressure Rating

Class 2500, Max 6170 psig @ 100 F (Carbon Steel)

Temperature Rating

As per ANSI B16.34

Body Construction

Pressure Seal Bonnet, Outside Screw and Yoke
(Seal Welded Bonnet Option)

Other Constructions: Bellow Seals, Extended stem,
Live Loading Packing, etc.. available upon request.

Pup Piece welding or Extended ends available upon request.
Welded Flange Option available upon request.

Seats

Full/Half HF (Hardfaced Stellite #6) seats or
Non HF seats available

Operation

Manual - Handwheel Operator

Seat / Seal Leakage

Conform to API 598.

Design Specification

ASME B16.34

NACE MR-01-75 material (where required)

Materials to ASTM standards

Special Materials are available to customer requirements

Socket Weld Ends to ASME B16.11

Threaded Ends to ASME B1.20.1

End to End (L) dimensions are to manufacturer standard

Other End Option

Flange Ends to ANSI B16.5

Butt Weld Ends to ANSI B16.25

Face to Face to ANSI B16.10

Engineering Data

Materials

Cross Reference of ASTM Material Designation Between Cast and Equivalent Forge

ASTM FORGED	ASTM CAST
CARBON STEEL	
A105	A216 WCB
LOW TEMPERATURE STEEL	
A350 LF2	A352 LCB
	A352 LCC
ALLOY STEEL	
A182 F1	A217 WC 1
A182 F11	A217 WC 6
A182 F22	A217 WC 9
A182 F5	A217 C5
A182 F9	A217 C12
STAINLESS STEEL	
A182 F6	A217 CA15
A182 F304	A351 CF8
A182 F304L	A351 CF3
A182 F316	A351 CF8M
A182 F316L	A351 CF3M
A182 F347	A351 CF8C
DUPLEX STEEL STEEL	
A182 F51	A890 4A / A351 CD3MN
A182 F53	A351 CD4MCU
A182 F55	A995 CD3MWCuN
NICKEL ALLOY	
INCONEL 825 - B564 N08825	A484 CU 5MCuC
INCONEL 625 - B564 N06625	A494 CW6MC
MONEL 400 - B564 N04400	A494 M35-1

Important Note: Data provided on this chart is for information purposes only. Always refer to current ASTM standards to verify information and cross reference data.

Pressure Temperature Rating

PRESSURE TEMPERATURE RATING FOR ASTM A105

SERVICE TEMPERATURE		CLASS 150	CLASS 300	CLASS 600	CLASS 800	CLASS 1500	CLASS 2500
°F	°C	psi	psi	psi	psi	psi	psi
-20 to 100	-29 to 38	285	740	1480	1975	3705	6170
200	93	260	680	1360	1810	3395	5655
300	149	230	655	1310	1745	3270	5450
400	204	200	635	1265	1690	3170	5280
500	260	170	605	1205	1610	3015	5025
600	316	140	570	1135	1515	2840	4730
650	343	125	550	1100	1465	2745	4575
700	371	110	530	1060	1415	2665	4425
750	399	95	505	1015	1350	2535	4230
800	427	80	410	825	1100	2055	3430
850	454	65	320	640	850	1595	2655
900	482	50	230	460	615	1150	1915
950	510	35	135	275	365	685	1145
1000	538	20	85	170	225	430	715

Note: ASME B16.34 Group 1.1. For A105, permissible, but not recommended for prolonged use above 800°F

PRESSURE TEMPERATURE RATING FOR ASTM A182 F316

SERVICE TEMPERATURE		CLASS 150	CLASS 300	CLASS 600	CLASS 800	CLASS 1500	CLASS 2500
°F	°C	psi	psi	psi	psi	psi	psi
-20 to 100	-29 to 38	275	720	1440	1920	3600	6000
200	93	235	620	1240	1655	3095	5160
300	149	215	560	1120	1495	2795	4660
400	204	195	515	1025	1370	2570	4280
500	260	170	480	955	1275	2390	3980
600	316	140	450	900	1205	2255	3760
650	343	125	440	885	1180	2210	3680
700	371	110	435	870	1160	2170	3620
750	399	95	425	855	1140	2135	3560
800	427	80	420	845	1125	2110	3520
850	454	65	420	835	1115	2090	3480
900	482	50	415	830	1105	2075	3460
950	510	35	385	775	1030	1930	3220
1000	538	20	365	725	970	1820	3030

Note: ASME B16.34 Group 2.2. A182 F316.

PRESSURE TEMPERATURE RATING FOR ASTM A182 F51

SERVICE TEMPERATURE		CLASS 150	CLASS 300	CLASS 600	CLASS 800	CLASS 1500	CLASS 2500
°F	°C	psi	psi	psi	psi	psi	psi
-20 to 100	-29 to 38	290	750	1500	2000	3750	6250
200	93	260	745	1490	1985	3720	6200
300	149	230	665	1335	1780	3335	5560
400	204	200	615	1230	1640	3070	5120
500	260	170	580	1160	1545	2905	4840
600	316	140	555	1115	1485	2785	4640
650	343	125	545	1095	1460	2735	4560
700	371	110	540	1085	1445	2710	4520
750	399	95	530	1065	1420	2660	4430

Note: ASME B16.34 Group 2.8. This steel may become brittle after service at moderately elevated temperatures. Not to be used over 600°F

VHV®

CHINA VIHUNG VALVE CO., LTD.

Address: Anfeng Industrial Park, Oubei, Yongjia,
Wenzhou Zhejiang, China. 325100

Tel: (86) 577 6798 9865

Fax" (86) 577 6798 9875

Email: vihung@vihung.com export@vihug.com

Website: www.vihung.com